

Zenith

Ombre



By Zenith Design Studio





Designed for the full spectrum workspace

Ombre by Zenith Design Studio is inspired by the idea of seamless transition just like the gradient it's named after. In today's evolving workplace, where focus, collaboration and flexibility coexist, Ombre workstations are designed to support blended workstyles with ease. Whether working solo or as part of a team, Ombre enables a natural shift between different modes of work, creating a workspace that feels fluid, intuitive and connected.



Workstations for a World in Transition

From individual desks to expansive linear runs, dynamic pie configurations and collaborative Pods, Ombre adapts effortlessly to a wide range of workplace needs. Available in both fixed height and electric adjust options, it empowers users to tailor their environment for comfort and productivity. This flexibility makes Ombre a future-ready solution for organisations navigating constant change.



Different Workspace Typologies

Ombre is purpose-built to support diverse environments, from high-performance workstations to creative ideation zones. Its adaptable configurations foster collaboration in shared spaces while maintaining the structure and durability required for everyday use. Whether facilitating teamwork or focused tasks, Ombre creates a cohesive foundation across the entire workplace.



Cable Management Made Clean and Effortless

Advanced cable management solutions are integral to Ombre's clean, seamless aesthetic. Hinged cable trays with tool-free access, integrated ducts and leg-mounted covers neatly conceal wiring and control boxes, delivering a streamlined, clutter-free workspace that enhances both functionality and design.



Ombre is a workstation system designed for the realities of modern work where flexibility, performance and longevity are essential. Bringing together robust engineering, seamless adaptability and refined design, it supports the full spectrum of workstyles with ease. Built to evolve alongside changing needs, Ombre delivers a future-ready solution that empowers organisations to create workplaces that are both functional and enduring.

MATERIALS

Worktop: MDF or particle board

Leg & Frame: Steel

FINISHES

Worktop: 25mm Standard laminate, veneer or custom top

Leg & Frame: Powder coated in Zenith Select Finishes

Plastic Parts Cool White & Black

LEG TYPES

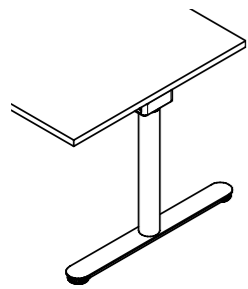

C-Series



DIMENSIONS

180 DEGREE - RUNS

Length Range per desk: 1200-2400mm
Depth Range: 600-900mm
Height Range: 620-1230 (Electric Adjust)
720mm (Fixed Height)
*Available in Fixed Height only

Note: Height range includes 25mm worktop

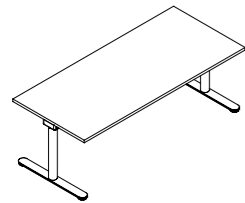

180 Degree

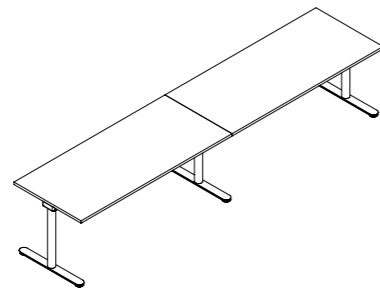

Run of 2*

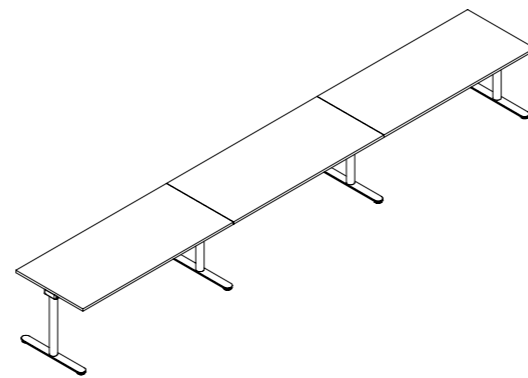

Run of 3*

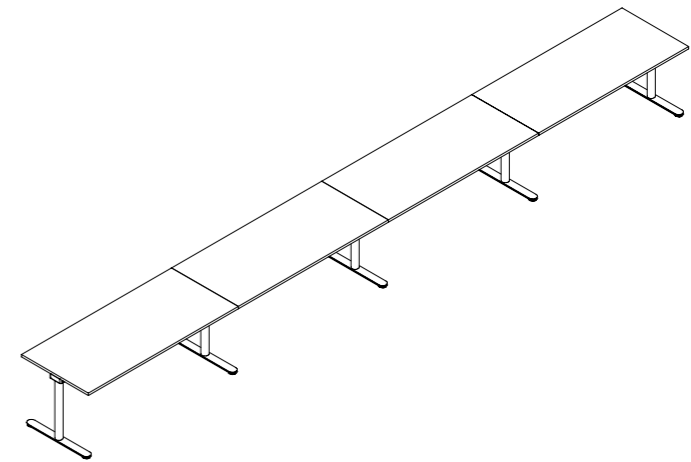

Run of 4*

180 DEGREE - PODS

Length Range per desk: 1200-2400mm
Depth Range: 600-900mm
Overall Depth: 1225-1890mm
Height Range: 620-1230 (Electric Adjust)
720mm (Fixed Height)
*Available in Fixed Height only

Note: Height range includes 25mm worktop

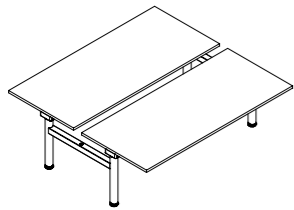

Pod of 2

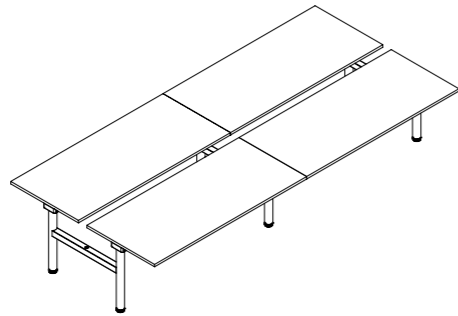

Pod of 4*

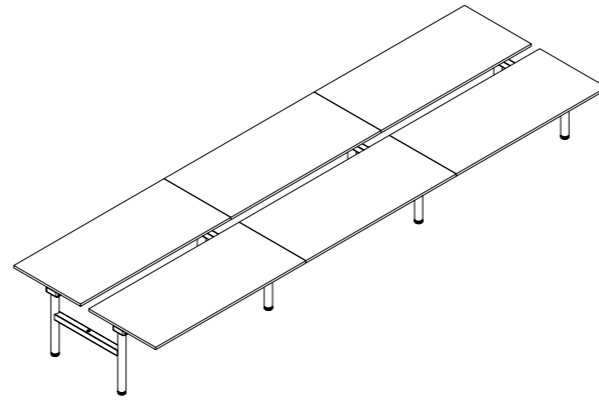

Pod of 6*

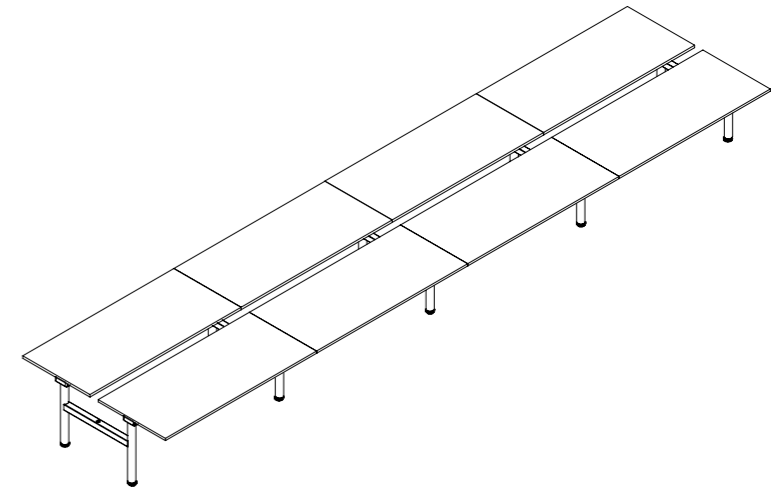

Pod of 8*

PIE SHAPE - PODS

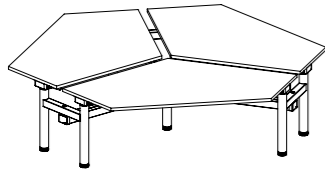

Tri-Pod 3

Worktop Length: 1100mm-1300mm
Worktop Depth: 500mm-600mm
Overall Depth: 1025mm-1300mm
Height Range: 620-1230mm (Electric Adjust)
720mm (Fixed Height)

Note: Height range includes 25mm worktop

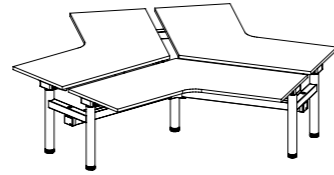

120-Pod 3

Worktop Length: 1100mm-1300mm
Worktop Depth: 600mm-750mm
Overall Depth: 1225mm-1600mm
Height Range: 620-1230mm (Electric Adjust)
720mm (Fixed Height)

Note: Height range includes 25mm worktop

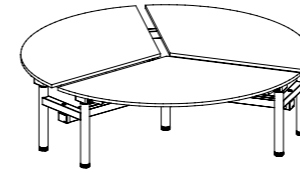

RND-Pod 3

Worktop Length: 1100mm-1300mm
Worktop gap: 75-100mm
Height Range: 620-1230mm (Electric Adjust)
720mm (Fixed Height)

Note: Height range includes 25mm worktop

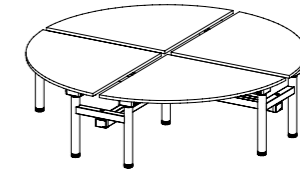

RND-Pod 4

Worktop Length: 1100mm-1250mm
Worktop gap: 25-100mm
Height Range: 620-1230mm (Electric Adjust)
720mm (Fixed Height)

Note: Height range includes 25mm worktop

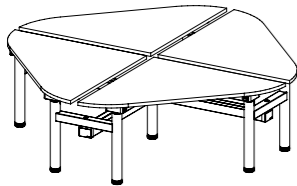

SQR-Pod 4

Worktop Length: 1100mm-1300mm
Worktop gap: 25-100mm
Height Range: 620-1230mm (Electric Adjust)
720mm (Fixed Height)

Note: Height range includes 25mm worktop

Zenith

Design

Studio

Understanding and collaborating with the client ensures all outcomes are achieved.

ZENITH's capacity to research, prototype and test products is an integral part to their design process. By putting an emphasis on researching global trends and anticipating the ever-changing climate of technology in the work environment, ZENITH not only responds to demands in the market but pioneers and innovate.

With the capability and facilities to manufacture locally, ZENITH products are exceptionally designed, customised and thoroughly tested for product suitability and usability to suit individual needs and user requirements.



Zenith

We've worked with interior designers, architects and workplace curators for many years. Together, we've developed a range of internal workspace environments. We work alongside these curators of modern workspaces to redefine the environments where people live, work, socialise, interact and learn.

Contemporary workplaces have to combine leading edge technology and physical elements in a way that produces productive environments for organisations. And every organisation is unique. So before we recommend a solution, we work hard to understand the organisation and the people who define its culture.

Our local teams and showrooms deliver the support you need. Our global logistics guarantees the highest quality product, service and delivery schedules.

Showroom locations

Australia Melbourne, Sydney, Canberra, Brisbane, Perth, Adelaide

New Zealand Auckland, Wellington, Christchurch

Asia Hong Kong, Shanghai, Singapore

zenithinteriors.com