

SMARTALOCK

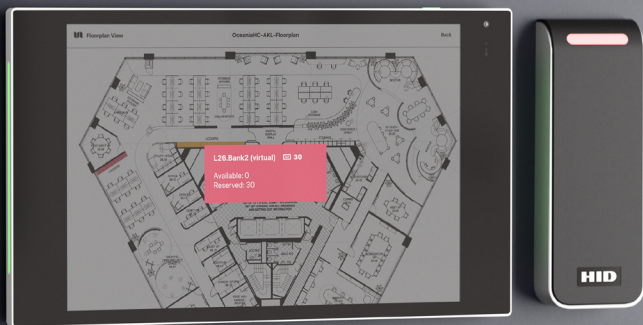

Features:

The Smartalock system is the modern smart locker for efficient use of personal and shared locker storage space.

Combining intelligent electronic lock hardware with powerful applications in a complete package - Smartalock is the electronic "smart lock" that can be retrofitted into existing lockers or installed on new lockers. No visible lock or handle is required with smartphones, existing swipe cards or the Touchscreen Kiosk, all standard options to dynamically allocate and access lockers.

Kiosk features a floorplan view to visualise locker bank locations and available lockers across a single floor.

The Primary Controller hardware supports up to 5000 locks and is supported with an Internal tamper proof alarm to protect the users privacy.

Smartalock ensures building access codes and employees smartphones work seamlessly with accessing the lockers, rather than using a pin.

Smartalock can work as an independent standalone system, or it can connect to office networks and building card systems via its built in WIFI or dedicated LAN port.

Options:

- Integrated UPS backup battery pack

Design: AGILE WORKSPACE

Warranty: 2 years (Up to 5 years extended warranty)
(Refer to Floorsense Warranty Document for more details)



Dimensions:

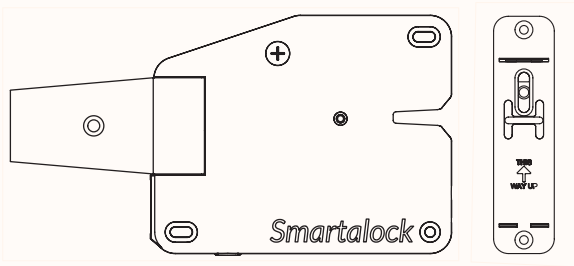

Lock Unit with Hub SL-L2-V4

OW 86mm
OD 27mm
OH 100mm

Powerful Hardware:

- POE Cables for lockers with combined power and data
- Card Reader supports both 13.56mhz and 125khz cards
- WIFI or LAN connectivity to a backhaul network for large systems
- Stand alone USB WIFI for small systems
- Powerful Primary Controller hardware supports up to 5000 locks
- Internal tamper proof alarm
- Optional integrated 24hr battery life UPS Pack for system backup

Full Featured Lock Module

- Left or right side mounting for flexible cabinetry design
- Soft open doors - pops open 2-3 inches
- Allows for no-visible-handle designs.
- Internal bright white LED lighting to easily see inside locker
- Power out mechanical override option
- Self adjusting lock designed for structural creep over time

Simple Yet Powerful Apps

- Shake to unlock. Simply shake smartphone when approaching locker bank to open door
- Simple 2 step enrolment process for end users
- Powerful analytics and usage reports built in

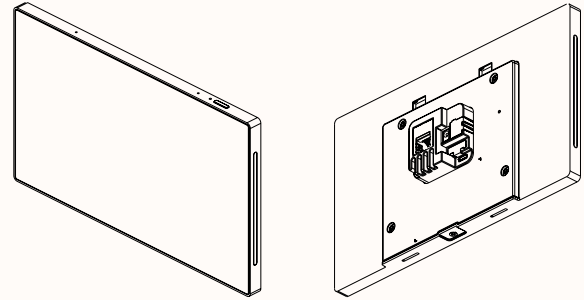

Smartalock Kiosk v3 Tablet

8" inch Screen

Features to the Kiosk V3:

- High quality screen - 8" screen with great performance
- Small overall footprint allows for flexible placement and a built in swipe card reader
- No requirement to place near controller, runs independently of slave controller
- No requirement for GPO - runs on single PoE cable
- Improved end user software interface - easier to use and more customisable
- Floorplan view - features a floorplan view to visualise locker bank locations and available lockers across a single floor.